

ICP05V1.1

- iBoard Lite

1. Introduction and overview

iCP05 offers unprecedented level of performance, reliability and scalability for Microchip PIC IO Kit solution. By the same time, it allows users to program their hex code into the well-known 28-Pin Flash PIC MCU by using commonplace ICSP (In-Circuit Serial Programming) connection method. The features of iCP05 are listed as followings.

- Easy interfacing, high performance and user friendly device
- Used for programming the popular 28-Pin Flash PIC MCU, includes PIC16F and PIC18F family
- Excellent flexibility that allows user to expand the board with plug and play modules

iBoard Features:

- **NCP1117** - provide **+5V or +3.3V Mode** voltage selection to PIC Microcontroller
- **20MHz crystal** - allow PIC run at maximum speed
- **Tact Switch** - PIC reset circuit
- **On/Off button** - power on off switch
- **Green LED** - power on indicator
- **Red LED** - 3.3V mode
- **Screw Terminal** - direct wiring connection (battery connection)
- **VS1 and VS2** - different input power supply (PIC supply and external module supply)
- **ICSP Connector** - on-board PIC programming
- **LCD Display Port** - direct LCD connection with LED backlight control
(LCD Module is not provided)
- **28-Pin IC Socket** - board-mounted female connectors
- **Supply Measurement** - detect input voltage level

Peripheral Features:

- **IO Port** (VDD - IO1 - IO2 - IO3 - IO4 - GND) - 5 channels
- **IO Port** (VSS - IO1 - IO2 - IO3 - IO4 - GND) - 3 channels
- **Analog Port** (GND - VDD - ADC) - 8 channels
- **Servo Motor Port** (GND - VSS - IO) - 4 channels
- **SPI Port** (VDD - SS - SCK - SDI - SDO - GND) - 1 channel
- **I2C Port** (VDD - SCL - SDA - IO1 - IO2 - GND) - 1 channel
- **USART Port** (VDD - IO1 - IO2 - TX - RX - GND) - 1 channel
- **Stepper Motor Port** (ULN2003A – 500mA Darlington driver):
(VDD - O1 - O2 - O3 - O4 - GND) + (VSS - O5 - O6 - O7 - IO8 - GND) - 1 channel
- **DC Motor Port** (L293D – with speed and direction (forward/reverse) control):
(VDD - O1 - PWM2 - PWM1 - O2 - GND) + (VSS - IO3 - IO4 - IO7 - IO8 - GND) - 1 channel

- **Boost/Buck Converter** (VS1 - VS1 - GND - GND - VS2 - VS2) - 1 channel
- **Off-board On/Off Switch** - SW1 (VS1 Power Supply), SW2 (VS2 Power Supply)

Dimension:

- Dimension: 10cm X 5.5cm
- Standard 2.54mm Pin Socket for ICSP connection

Support Devices:

- **28-Pin PIC MCU:** PIC16F57, PIC16F72, PIC16F73, PIC16F722, PIC16F723, PIC16F726, PIC16F737, PIC16F767, PIC16F870, PIC16F872, PIC16F873A, PIC16F882, PIC16F883, PIC16F886, PIC16F913, PIC16F916, PIC16F1933, PIC16F1936, PIC16F1938, PIC18F2220, PIC18F2221, PIC18F2320, PIC18F2321, PIC18F2331, PIC18F2410, PIC18F2420, PIC18F2423, PIC18F2431, PIC18F2450, PIC18F2455, PIC18F2458, PIC18F2480, PIC18F2510, PIC18F2515, PIC18F2520, PIC18F2523, PIC18F2525, PIC18F2550, PIC18F2553, PIC18F2580, PIC18F2585, PIC18F2610, PIC18F2620, PIC18F2680, PIC18F2682, PIC18F2685

1.1 iBoard layout

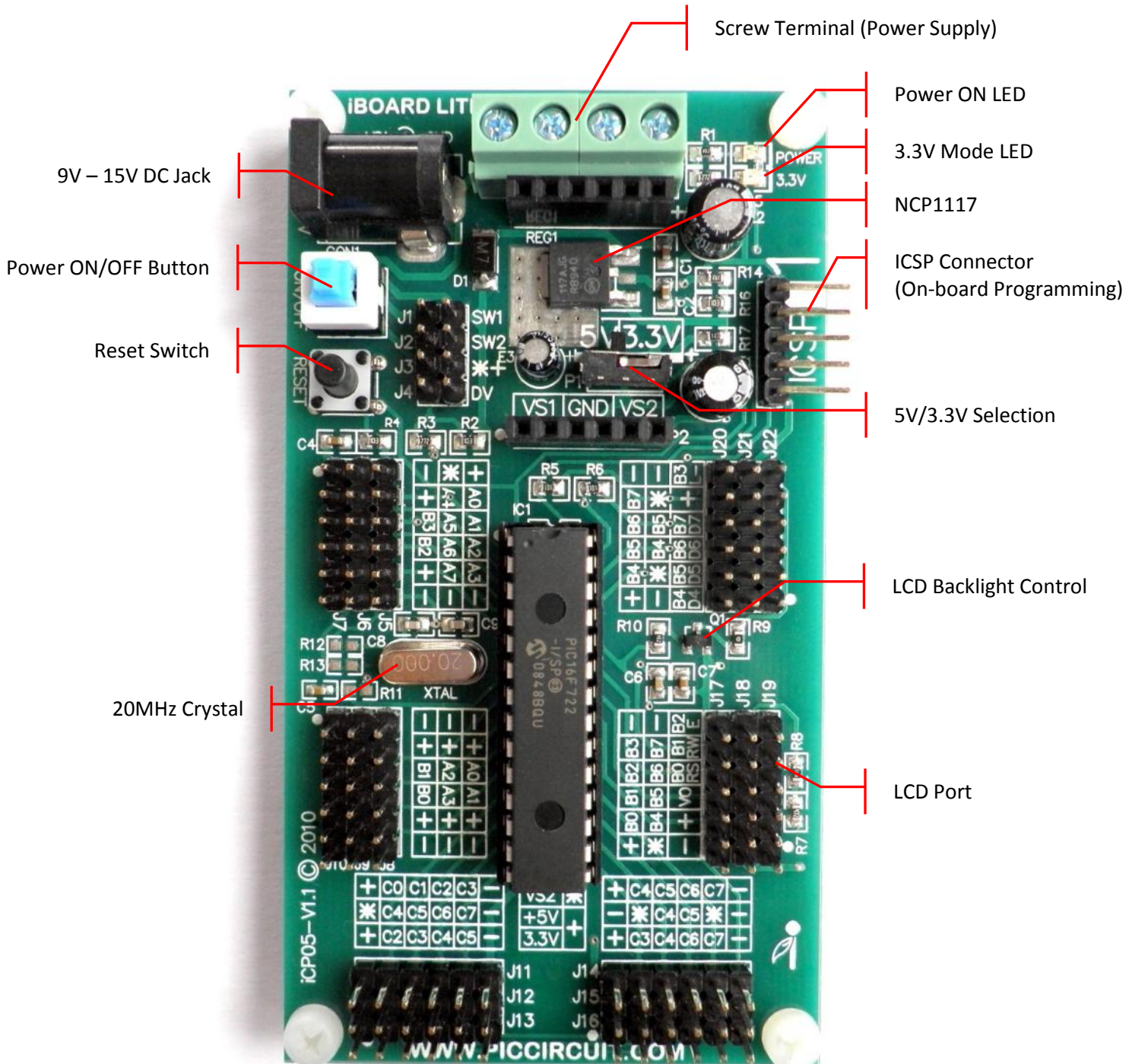

1.2 Peripheral layout

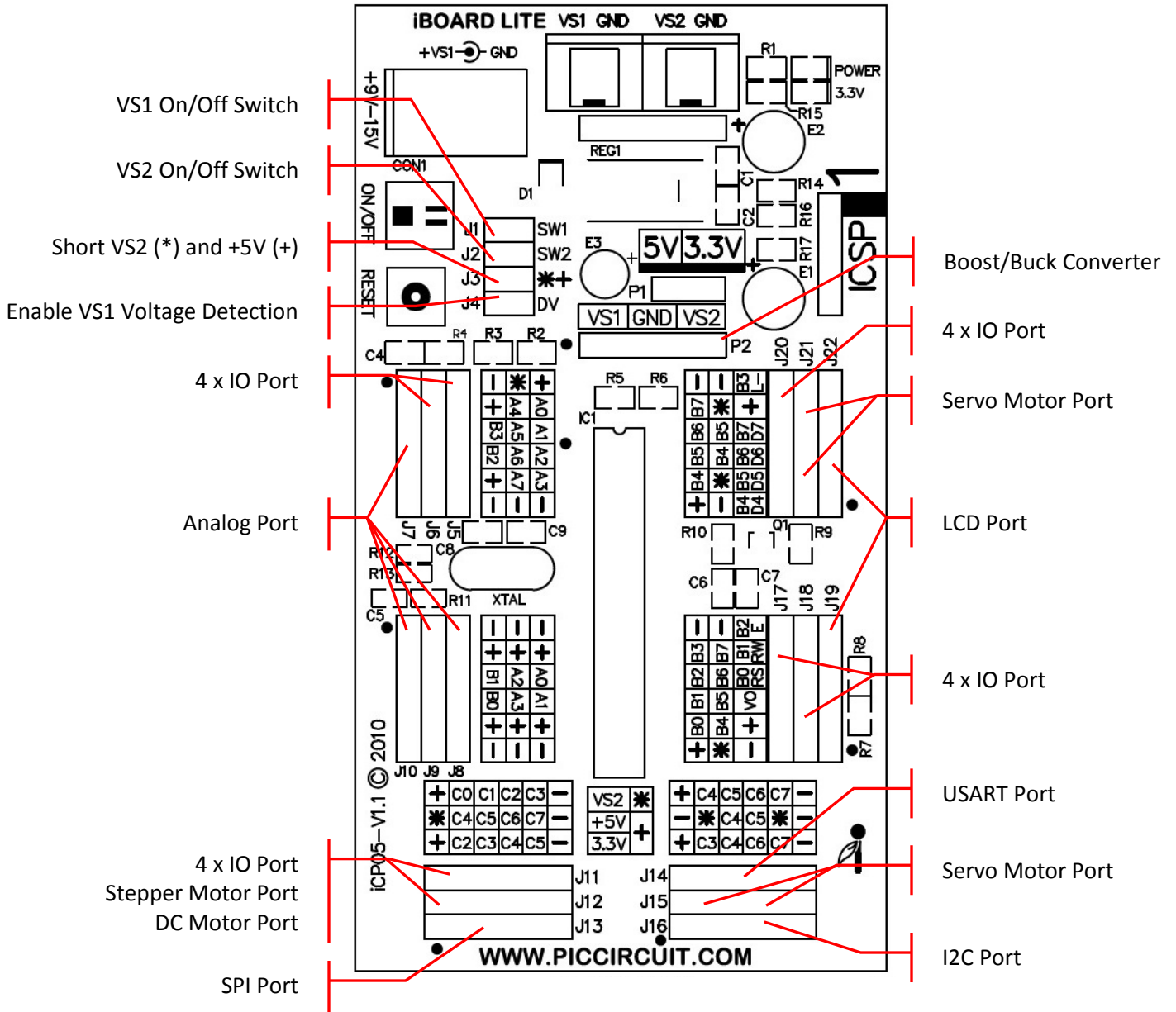

2. Schematic Diagram

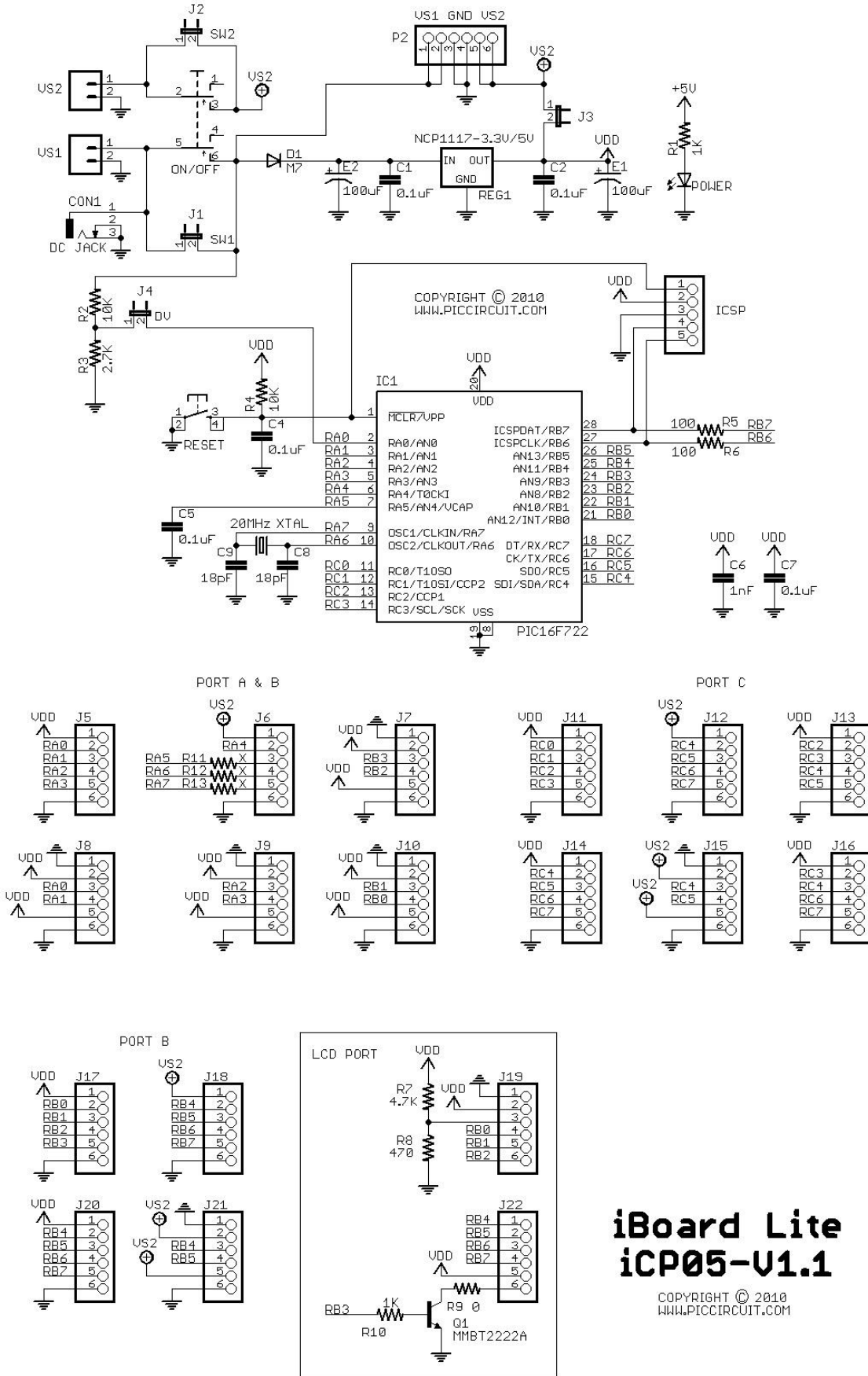

iBoard Lite ICP05-U1.1

COPYRIGHT © 2010 WWW.PICCIRCUIT.COM

3. Peripheral Connection

Port	Label	Description
J1	SW1	Off board On/Off Switch for supply VS1
J2	SW2	Off board On/Off Switch for supply VS2
J3	*+	Connect VS2(*) to +5V(+) Do not short it if VS2 is connected to external supply
J4	DV	Enable VS1 Voltage Detection

IO Port

Port	Pin 1	Pin 2	Pin 3	Pin 4	Pin 5	Pin 6	Description
J5	+	A0	A1	A2	A3	-	Digital I/O
J6	*	A4	A5	A6	A7	-	Digital I/O
J11	+	C0	C1	C2	C3	-	Digital I/O
J12	*	C4	C5	C6	C7	-	Digital I/O
J14	+	C4	C5	C6	C7	-	Digital I/O
J17	+	B0	B1	B2	B3	-	Digital I/O
J18	*	B4	B5	B6	B7	-	Digital I/O
J20	+	B4	B5	B6	B7	-	Digital I/O

Sensor/Analog Port

Port	Pin 1	Pin 2	Pin 3	Pin 4	Pin 5	Pin 6	Description
J7A	-	+	B3				AN9
J7B				B2	+	-	AN8
J8A	-	+	A0				AN0
J8B				A1	+	-	AN1
J9A	-	+	A2				AN2
J9B				A3	+	-	AN3
J10A	-	+	B1				AN10
J10B				B0	+	-	AN12

Servo Motor Port

Port	Pin 1	Pin 2	Pin 3	Pin 4	Pin 5	Pin 6	Description
J15A	-	*	C4				Servo Motor Port
J15B				C5	*	-	Servo Motor Port
J21A	-	*	B4				Servo Motor Port
J21B				B5	*	-	Servo Motor Port

Communication Port

Port	Pin 1	Pin 2	Pin 3	Pin 4	Pin 5	Pin 6	Description
J13	+	C2/SS	C3/SCK	C4/SDI	C5/SDO	-	SPI Port
J14	+	C4	C5	C6/TX	C7/RX	-	USART Port
J16	+	C3/SCL	C4/SDA	C6	C7	-	I2C Port

Motor Driver Port

Port	Pin 1	Pin 2	Pin 3	Pin 4	Pin 5	Pin 6	Description
J11	+	C0	C1	C2	C3	-	Stepper Motor
J12	*	C4	C5	C6	C7	-	
J11	+	C0	C1/PWM2	C2/PWM1	C3	-	DC Motor
J12	*	C4	C5	C6	C7	-	

LCD Port

Port	Pin 1	Pin 2	Pin 3	Pin 4	Pin 5	Pin 6	Description
J19	-	+	VO	B0/RS	B1/RW	B2/E	LCD Command Port
J22	B4/D4	B5/D5	B6/D6	B7/D7	+	B3/L-	LCD Data Port

Disclaimer

iCircuit Technologies has an ongoing policy to improve the performance and reliability of their products; we therefore reserve the right to make changes without notice. The information contained in this data sheet is believed to be accurate however we do not assume any responsibility for errors or any liability arising from the application or use of any product or circuit described herein. This data sheet neither states nor implies warranty of any kind, including fitness for any particular application.

Copyright Notice

The copyright in this document is owned by, *iCircuit Technologies*. No part of parts hereof may be reproduced, distributed, republished, displayed, broadcast, hyperlinked or transmitted in any manner or by any means or stored in an information retrieval system without the prior written permission of *iCircuit Technologies*.

Any liability from defect or malfunction is limited to the replacement of product ONLY, and does not include labour or other incurred corrective expenses.

Using or continuing to use these devices hereby binds the user to these terms.

CONTACT INFORMATION

For further information or technical assistance please contact:

Web: <http://www.piccircuit.com>

Email: support@piccircuit.com